

TOP
collection

Boheme

idea: Aldo Mazzucato



1. SCOCCA:

Monoscocca in multistrato di legno di faggio o rovere, finitura laccata o verniciata, con sedile in spugna rivestita in tessuto

2. MECCANISMO:

Comando elevazione a gas, finitura nera

1. SHELL:

Bleach or durmast plywood monocoque, lacquered, painted foam padded seat cushion, fabric upholstery

2. MECHANISM:

Height adjustable, Black finish

1. COQUE:

Monocoque en multiplie de hêtre ou chaine, finition laqué ou vernie, assise en mousse et revêtue

2. MECANISME:

Réglable en hauteur, finition noir

1. SCHALE:

Buchen oder Eichen Holzschale, lackiert, gefärbt oder ausgepolstert mit Schwamm und Stoffbezug

2. MECHANIK:

Schwarze Sitzhöhenverstellung

1. CASCO

Monocasco en madera contrachapada de haya o roble, acabado lacado o barnizado, con asiento de rizo tapizado

2. MECANISMO:

Control de elevación de gas, acabado negro



Per approfondimenti su meccanismi e altre opzioni consulta la sezione Technical Informations a pag. 4

For more informations on mechanisms and other options, see the Technical Informations section on page 4

3. GAS:

- Regolabile in altezza, rotazione, finitura cromata
- Altezza fissa, ritorno automatico, finitura cromata

4. BASE:

- Base 4 razze in alluminio, Ø 630mm, finitura lucida
- Base 4 razze in ferro, Ø 720mm, finitura cromata (15µm)
- Base a disco in lastra d'acciaio, Ø480mm, finitura cromata (15µm)
- Base 4 gambe a ragno in tubo d'acciaio Ø 20mm, finitura cromata (15µm)
- Base 4 gambe in tubo d'acciaio Ø 12mm, finitura cromata (15µm)

5. RUOTE/PIEDINI:

- Ruote Ø 50mm, autofrenanti o autofrenanti e gommate, finitura cromata
- Tappi in polipropilene, finitura nera o bianca
- Piedini snodati in poliamide, finitura cromata (15µm), nera o bianca
- Piedini in polimero termoplastico, h. 25mm, finitura cromata (15µm)
- Piedini in polimero termoplastico, h. 40mm, finitura cromata (15µm)
- Feltrini

3. GAS LIFT:

- Height adjustable, swivel, chromed finish
- Not height adjustable, memory return cylinder, chromed finish

4. BASE:

- Iron 4 spoke base, Ø 720 mm chromed finish (15µm)
- Round base, Ø480mm steel plate, chromed finish (15µm)
- 4 legs swivel base, Ø 22 mm steel tube, chromed finish (15µm)
- Polished aluminium 4 spoke base, Ø630 mm
- 4 legs base, Ø12mm steel tube, chromed finish (15µm)

5. CASTORS/FEET:

- Chromed soft self-braking castors d.50mm
- Polypropylene plugs, black or white finish
- Leveler glides in polyamide, chromed finishes (15µm), black or white
- h.25mm Thermoplastic polymer gliders chromed finish (15µm)
- h.40mm Thermoplastic polymer gliders, chromed finish (15µm)
- Felts

3. VERIN A GAZ:

- Réglable en hauteur, pivotant, finition chromé
- Hauteur fixe, retour automatique, finition chromé

4. PIÈTEMENT:

- Piètement 4 branches alu poli, Ø 630mm
- Piètement 4 branches en métal, Ø 720mm, finition chromé (15µm)
- Piètement disque en acier Ø 480mm, finition chromé (15µm)
- Piètement araigné 4 pieds en tube d'acier Ø 20mm, finition chromé (15µm)
- Piètement 4 pieds en tube d'acier Ø 12mm, finition chromé (15µm)

5. ROULETTES/PATINS:

- Roulettes d.50mm chromées gommées autofrein
- Tampons en polypropylène, finition noir ou blanc
- Patins articulés et polyamide, finition chromée (15µm), noir ou blanc
- Patins polymère thermoplastique, h.25mm, finition chromée (15µm)
- Patins polymère thermoplastique, h.40mm, finition chromée (15µm)
- Feutres

3. GASFEDER:

- Sitzhöhenverstellung, drehbar, verchromt
- Rückholmechanik ohne Sitzhöhenverstellung, verchromt

4. GESTELL:

- 4-Stern Alu poliertes Fußkreuz, Ø 630 mm
- 4-Stern Eisen Fußkreuz, Ø720mm verchromt (15µm)
- Stahlplatte Tellerfuß, Ø480mm, verchromt (15µm)
- 4-Fuß Drehkreuz, Ø20 mm Stahlrohr, verchromt (15µm)
- 4-Fuß Gestell, Ø12mm Stahlrohr, verchromt (15µm)

5. ROLLEN/GLEITER:

- Verchromte weiche gebremste Rollen D. 50mm
- Polyamid Gleiter, schwarz oder weiss
- Gelenkgleiter aus Polyamid, verchromt (15 µm), schwarz oder weiss
- Thermoplastische Polymergleiter, H.25mm, verchromt (15 µm)
- Thermoplastische Polymergleiter, H.40mm, verchromt (15 µm)
- Filzgleiter

3. GAS:

- Ajustable en altura, rotación, acabado cromado
- Altura fija, retorno automático, acabado cromado

4. BASE:

- Base de 4 radios en aluminio, Ø 630mm, acabado brillante
- Base de 4 estrellas en hierro, Ø 720 mm, acabado cromado (15 µm)
- Base de disco en chapa de acero, Ø480mm, acabado cromado (15 µm)
- Base 4 patas de araña en tubo de acero Ø 20 mm, acabado cromado (15 µm)
- Base de 4 patas en tubo de acero de 12 mm, acabado cromado (15 µm)

5. RUEDAS / PIES:

- Ruedas de Ø 50 mm, autofrenantes o blandas y autofrenantes, acabado cromado
- Tapones de polipropileno, acabado negro o blanco.
- Pies articulados en poliamida, acabado cromado (15 µm), blanco o negro
- Pies en polimero termoplástico, h. 25 mm, acabado cromado (15µm)
- Pies en polimero termoplástico, h. 40 mm, acabado cromado (15µm)
- Fieltros

ON REQUEST

Colonna a gas con ritorno ad altezza fissa

Not height adjustable memory return cylinder

Retour automatique sans réglage en hauteur

Rückholmechanik ohne Sitzhöhenverstellung

Columna de retorno automatico sin regulacion de altura

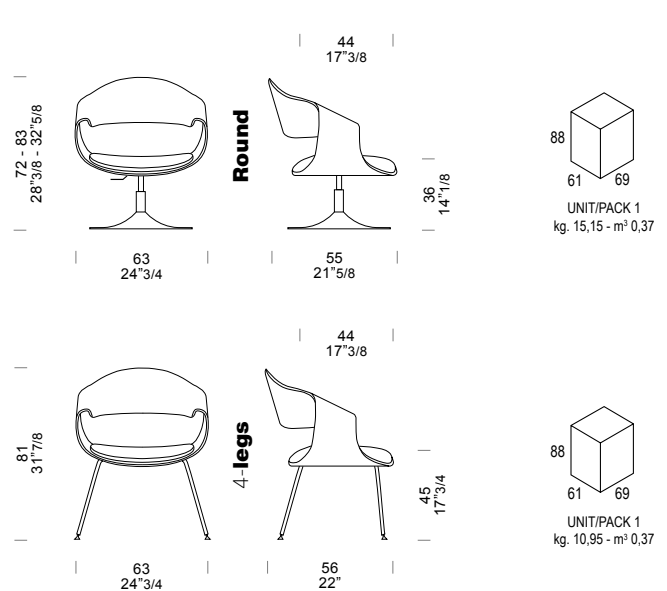
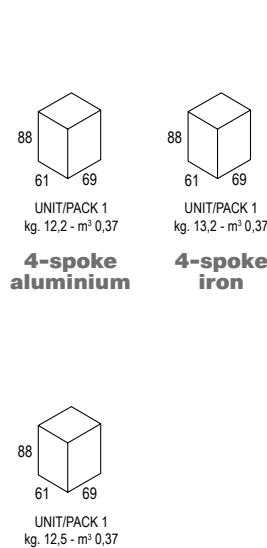
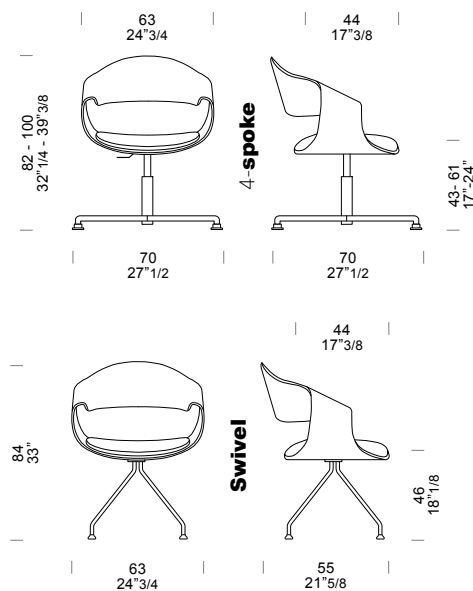

Pour plus d'informations sur les mécanismes et autre options, voir la section Informations techniques à la page 4

Für weitere Details zu Mechanik und Optionen siehe den Abschnitt Technische Informationen auf Seite 4

Para más informaciones sobre los mecanismos y otras opciones consulte la sección de Informaciones Técnica pag. 4